

# VERTO™

Making Sound Versatile

 martini

## Decorative Hanging Screen - Suspended Soffit and Tension Instructions

### Components:

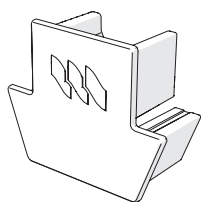

End Caps

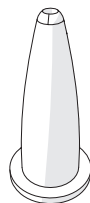

Eclipse Ceiling Ends



Concrete Dowel

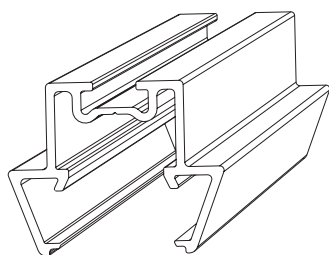

Aluminium Extrusion

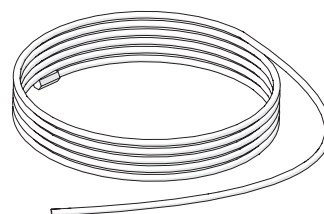

Suspension Wire

### Tools you'll need:

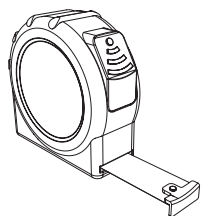

Measuring Tape

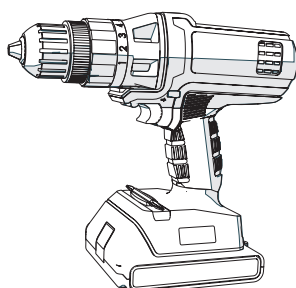

Drill

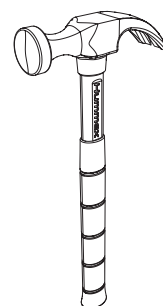

Hammer

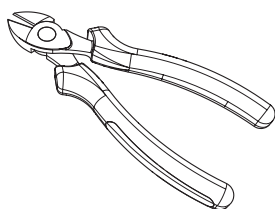

Side Cutters

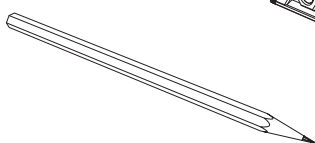

Pencil

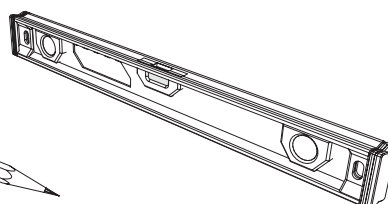

Level



### Step 1

Prepare area and use laser level to mark out desired location of screen.

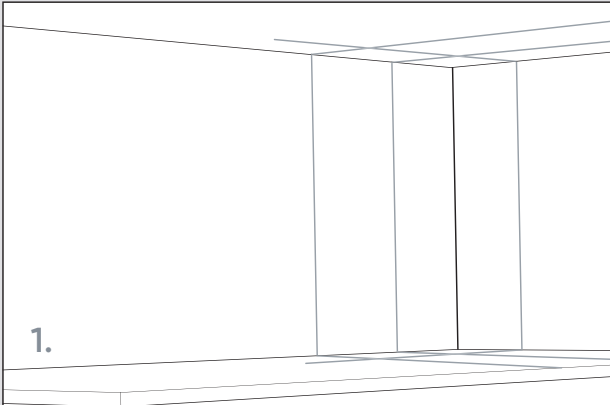

### Step 2 and 3

Measure out area and mark spacing for required hole. Drill a 30mm hole. Hammer concrete dowel into hole.

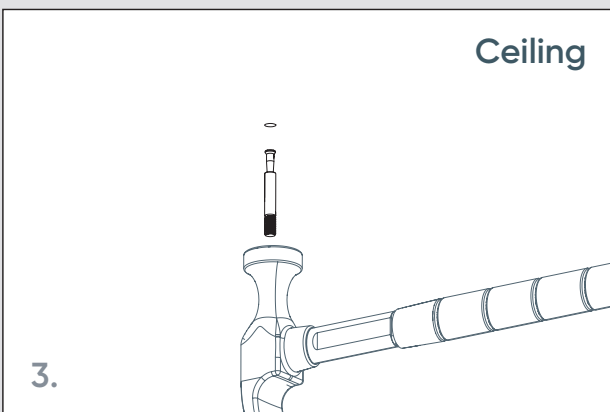
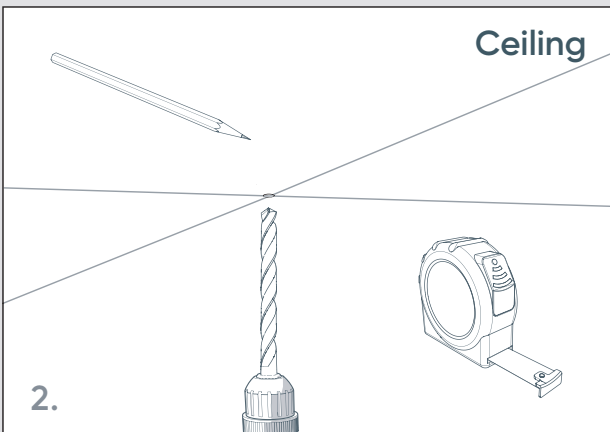

### Step 4

Insert Suspension Wire through the bottom of the Eclipse Ceiling End and pull Suspension Wire all the way through till the end knuckle is secured inside the Eclipse Ceiling End.

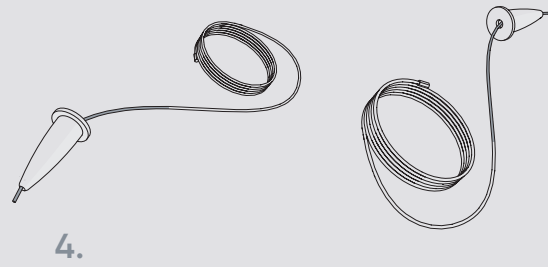

### Step 5 and 6

Screw Eclipse Ceiling End into Concrete Dowel. Ensure Eclipse is screwed all the way to the top of the dowel.

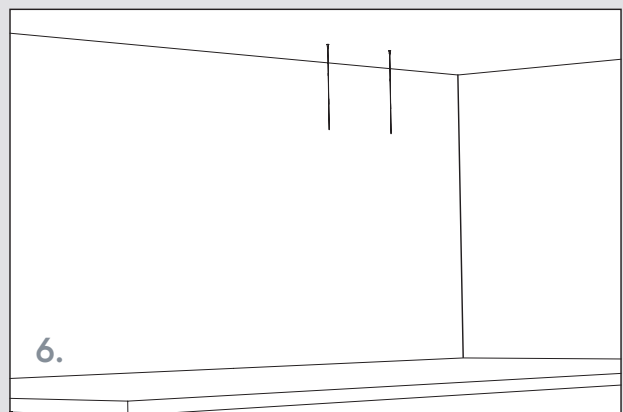

### Step 7

Friction fit aluminium extrusion to top (and bottom if required) of the decorative screen, ensuring it bottoms out on the aluminium.

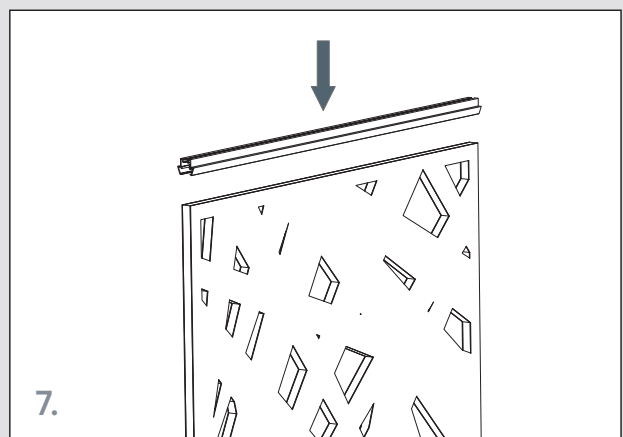

### Step 8 and 9

Slide in both Eclipse Rail Ends into aluminium extrusion. Insert end caps on either side of the aluminium extrusion.

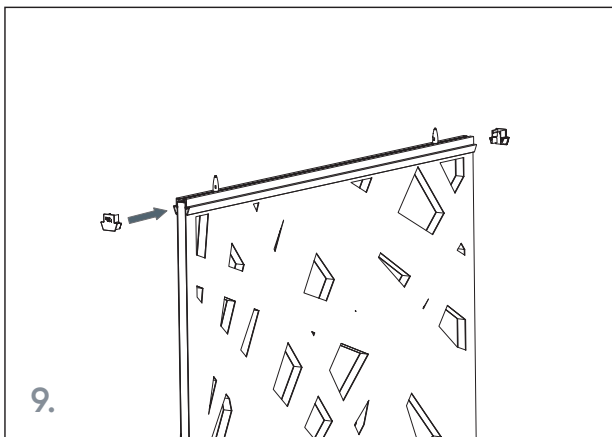
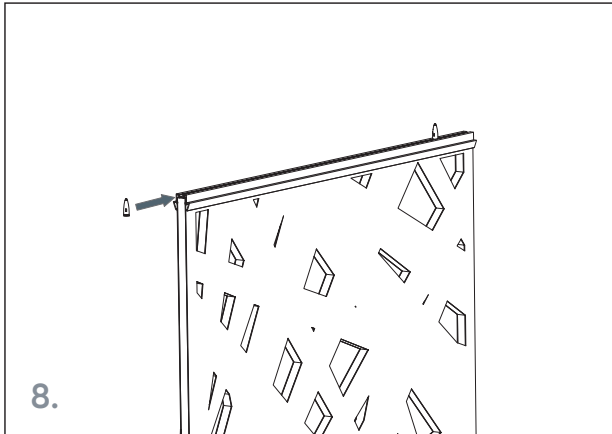

### Step 10

For additional fixing you can use the supplied screws to fix the panel through the aluminium.

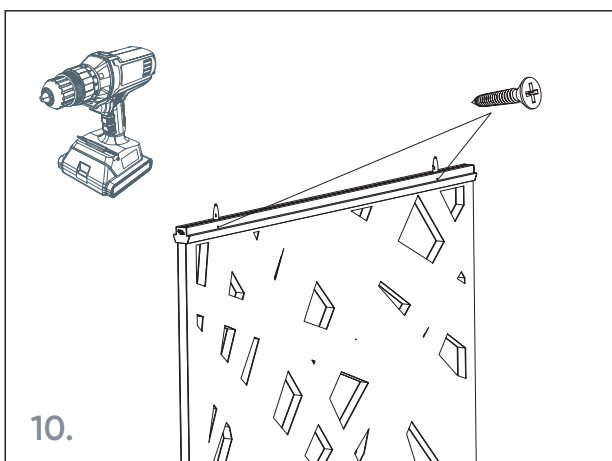

### Step 11

Insert Suspension Cord through the Eclipse Rail End already attached to the aluminium extrusion. Ensure the cord is threaded through the lower hole. Repeat step for all suspension cords.

### Step 12

Whilst supporting the suspension cord firmly with one hand, lift the aluminium extrusion to the required height ensuring it is level. Repeat step for other suspension cords.

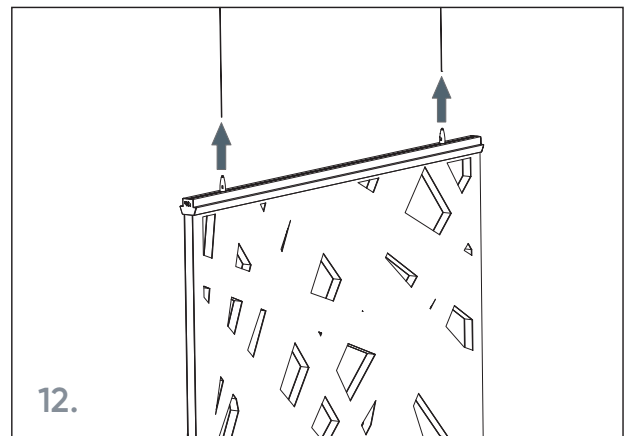

### Step 13

Once level and in position, cut off excess suspension cord with side cutters.

**NOTE:** Once you cut this excess suspension cord you can no longer lower the height of this system.  
**MAKE SURE YOU ARE 100% HAPPY WITH THIS HEIGHT BEFORE CUTTING CORD.**

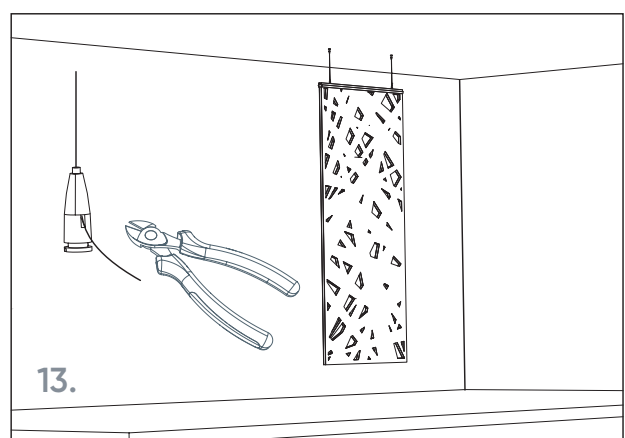

## IF TENSION FITTING TO THE FLOOR:

Repeat Steps 2-12 on the floor.  
Tension and cut bottom cords  
as per step 14 below.

### Step 14

Tension and cut bottom cords.

